

Trench Field-stop IGBT Discrete

Parameter	Value	Unit
V_{CE}	1350	V
I_C	30	A
$V_{CE(sat)}$	2.3	V

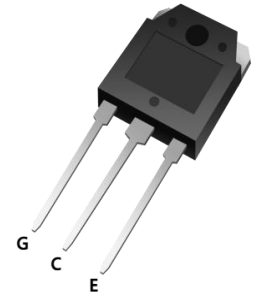
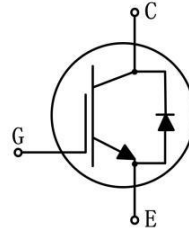

TO-3PN

Features

- Trench and Field-stop technology
- Low collector to emitter saturation voltage
- Optimized for Fast Switching
- Easy parallel switching capability
- Short circuit withstands time-10 μ s

Applications

- Induction Heating
- Soft switching application

Maximum Ratings (T_J= 25°C unless otherwise noted)

Symbol	Parameter	Test Condition	Value	Unit
V_{CES}	Collector to Emitter Voltage		1350	V
V_{GES}	Continuous Gate to Emitter Voltage		± 20	V
I_C	Continuous Collector Current	$T_C=100^\circ C$	30	A
		$T_C=25^\circ C$	60	A
I_{CM}	Pulse Collector Current	Pulse width limited by T _{Jmax}	120	A
P_D	Maximum Power Dissipation (IGBT)	$T_C=25^\circ C, T_J=150^\circ C$	347	W
t_{sc}	Short Circuit Withstand Time	$V_{CC}=600V, V_{GE}\leq 15V$	10	μ s

Electrical Characteristics of IGBT (T_J= 25°C unless otherwise noted)

Static characteristics

Symbol	Parameter	Test Condition	Min	Typ	Max	Unit
$V_{GE(th)}$	Gate-Emitter Threshold Voltage	$I_C=1mA, V_{CE}=V_{GE}, T_J=25^\circ C$	4.9	5.9	6.9	V
$V_{CE(sat)}$	Collector-Emitter Saturation Voltage	$I_C=30A, V_{GE}=15V, T_J=25^\circ C$	-	2.3	-	V
		$T_J=125^\circ C$	-	2.8	-	
I_{CES}	Collector-Emitter Leakage Current	$V_{GE}=0V, V_{CE}=V_{CES}, T_J=25^\circ C$	-	-	1.0	mA
I_{GES}	Gate-Emitter Leakage Current	$V_{GE}=\pm 20V, V_{CE}=0V, T_J=25^\circ C$	-100	-	100	nA
C_{iss}	Input capacitance	$V_{CE}=25V, V_{GE}=0V, f=1MHz$	-	2485	-	pF
C_{oss}	Output capacitance		-	157	-	
C_{riss}	Reverse transfer capacitance		-	72	-	
R_{gint}	Internal gate resistor			1.3		Ω

Switching Characteristics

$t_{d(on)}$	Turn-on Delay Time	$V_{CC}=600V, I_C=30A,$ $V_{GE}=\pm 15V, L=525\mu H,$ $R_g=4.8\Omega$	$T_j=25^\circ C$	21	ns
			$T_j=125^\circ C$	21	
t_r	Rise Time		$T_j=25^\circ C$	24	ns
			$T_j=125^\circ C$	25	
$t_{d(off)}$	Turn-off Delay Time		$T_j=25^\circ C$	93	ns
			$T_j=125^\circ C$	100	
t_f	Fall Time		$T_j=25^\circ C$	286	ns
			$T_j=125^\circ C$	360	
E_{on}	Turn-on Switching Loss		$T_j=25^\circ C$	3.0	mJ
			$T_j=125^\circ C$	3.3	
E_{off}	Turn-off Switching Loss	$T_j=25^\circ C$	1.5	mJ	
		$T_j=125^\circ C$	2.3		
$R_{\theta JC}$	Junction-To-Case (IGBT)		0.36	K/W	

Electrical Characteristics of Diode ($T_j = 25^\circ C$ unless otherwise noted)
Static characteristics

Symbol	Parameter	Test Condition	Min	Typ	Max	Unit
V_{FM}	Forward Voltage	$I_F=30A, V_{GE}=0V$	$T_j=25^\circ C$		2.4	V
			$T_j=150^\circ C$		2.6	

Switching Characteristics

I_{rr}	Peak Reverse Recovery Current	$I_F=30A,$ $V_{CC}=600V,$ $V_{GE}=-15V, L=525\mu H,$ $R_g=4.8\Omega$	$T_j=25^\circ C$	54	A
			$T_j=125^\circ C$	68	
Q_{rr}	Reverse Recovery Charge		$T_j=25^\circ C$	4.5	μC
			$T_j=125^\circ C$	7.3	
E_{rec}	Reverse Recovery Energy		$T_j=25^\circ C$	1.9	mJ
			$T_j=125^\circ C$	3.3	
$R_{\theta JC}$	Junction-To-Case(Diode)			0.95	K/W

Module Characteristics

T_j	Maximum Junction Temperature		150	$^\circ C$
T_{JoP}	Maximum Operating Junction Temperature Range	-55	+150	$^\circ C$
T_{stg}	Storage Temperature	-55	+150	$^\circ C$

Typical Characteristics

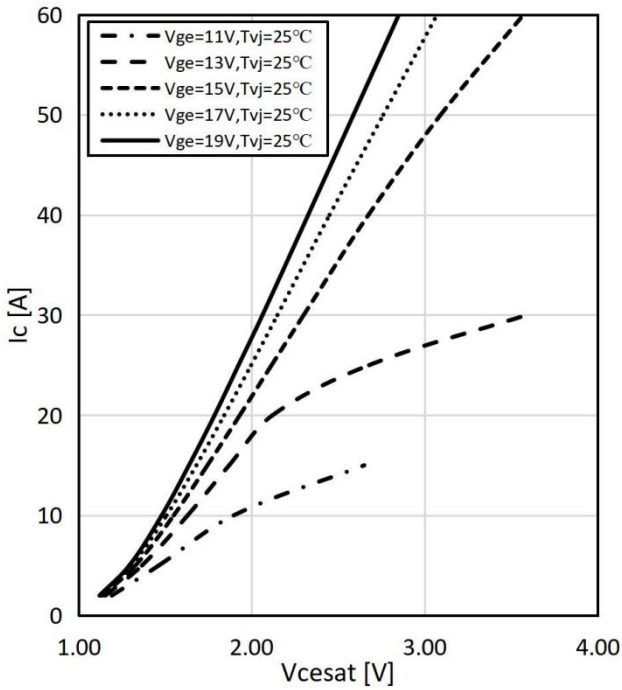

Fig.1 Output characteristic IGBT Inverter (typical)

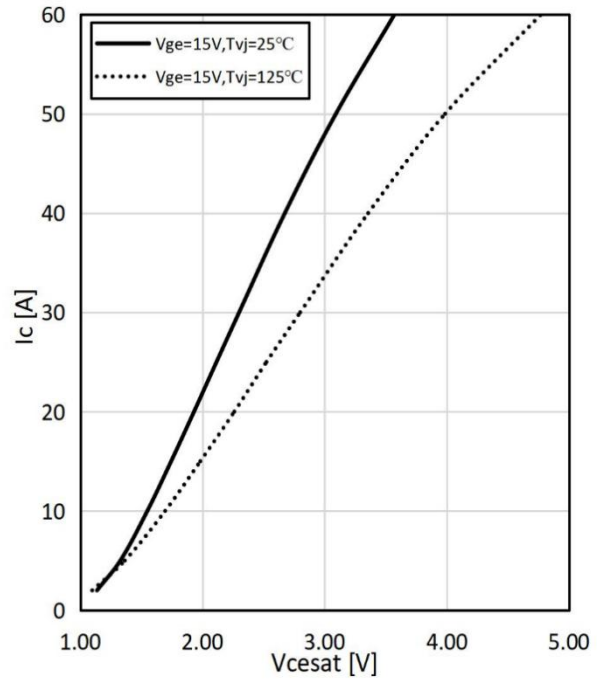

Fig.2 Output characteristic IGBT Inverter (typical)

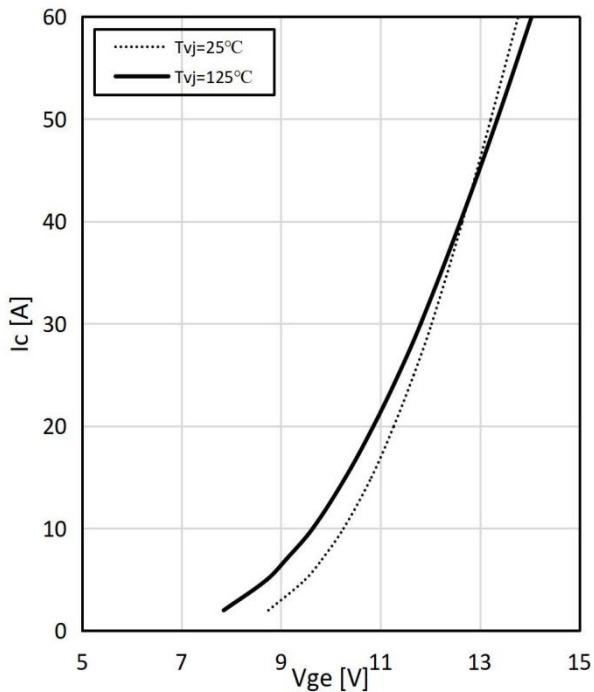

Fig.3 Transfer characteristic IGBT Inverter (typical)

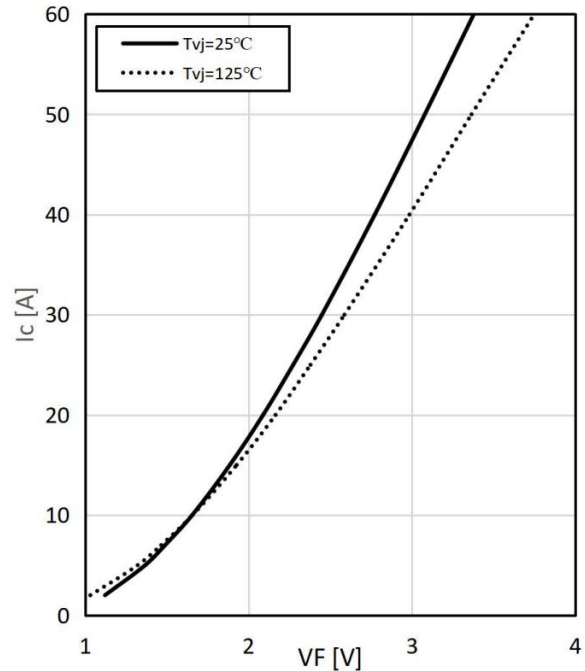

Fig.4 Forward characteristic of Diode Inverter (typical)

VCC=600V, VCE=±15V, RG=4.8Ω

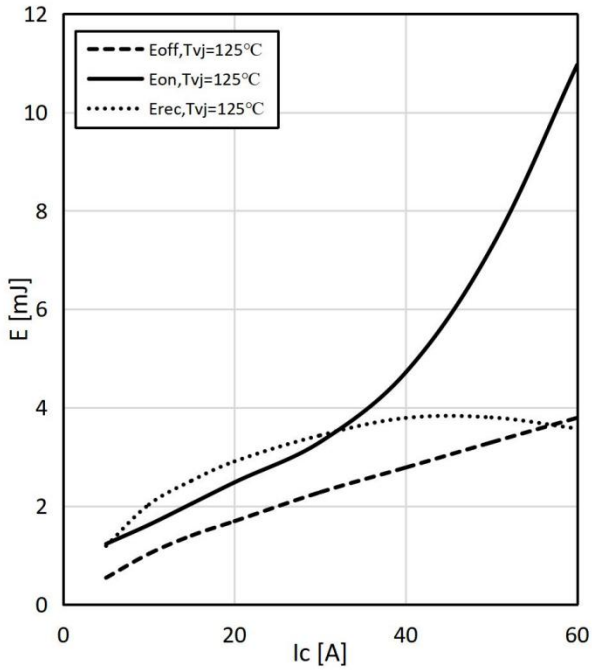

Fig.5 Switching losses IGBT Inverter (typical)

VCC=600V, VCE=±15V, Ic=30A

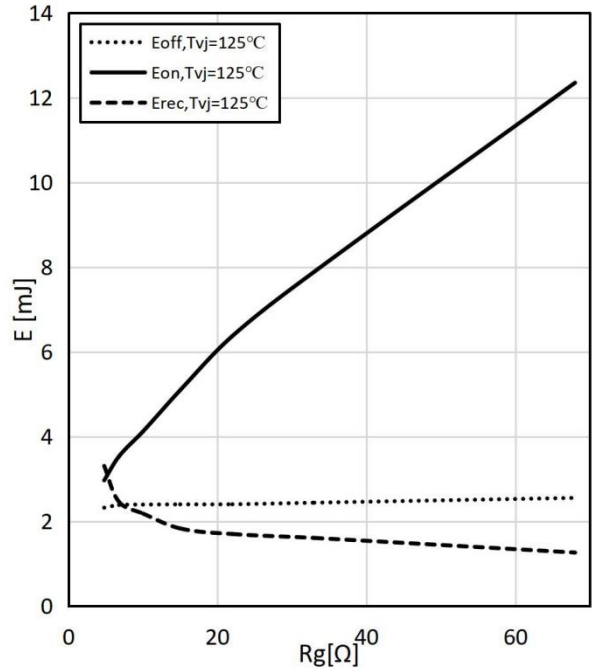

Fig.6 Switching Losses vs. Gate Resistance (typical)

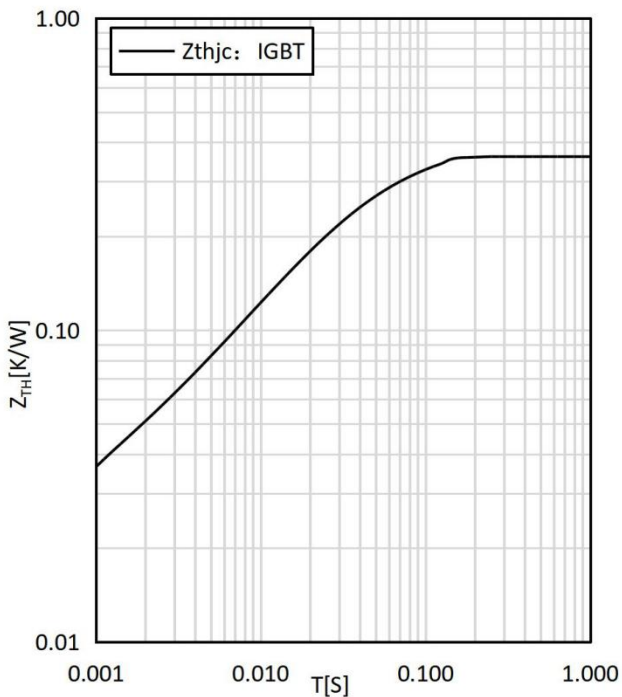

Fig.7 Transient thermal impedance IGBT

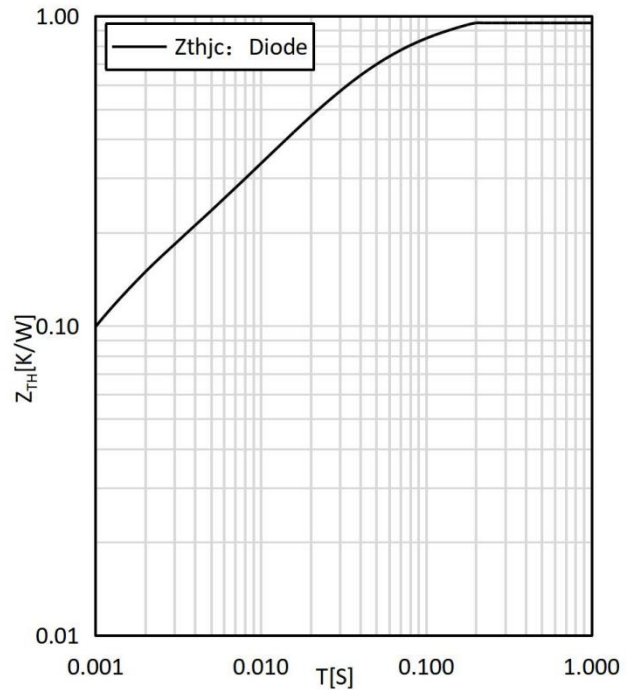
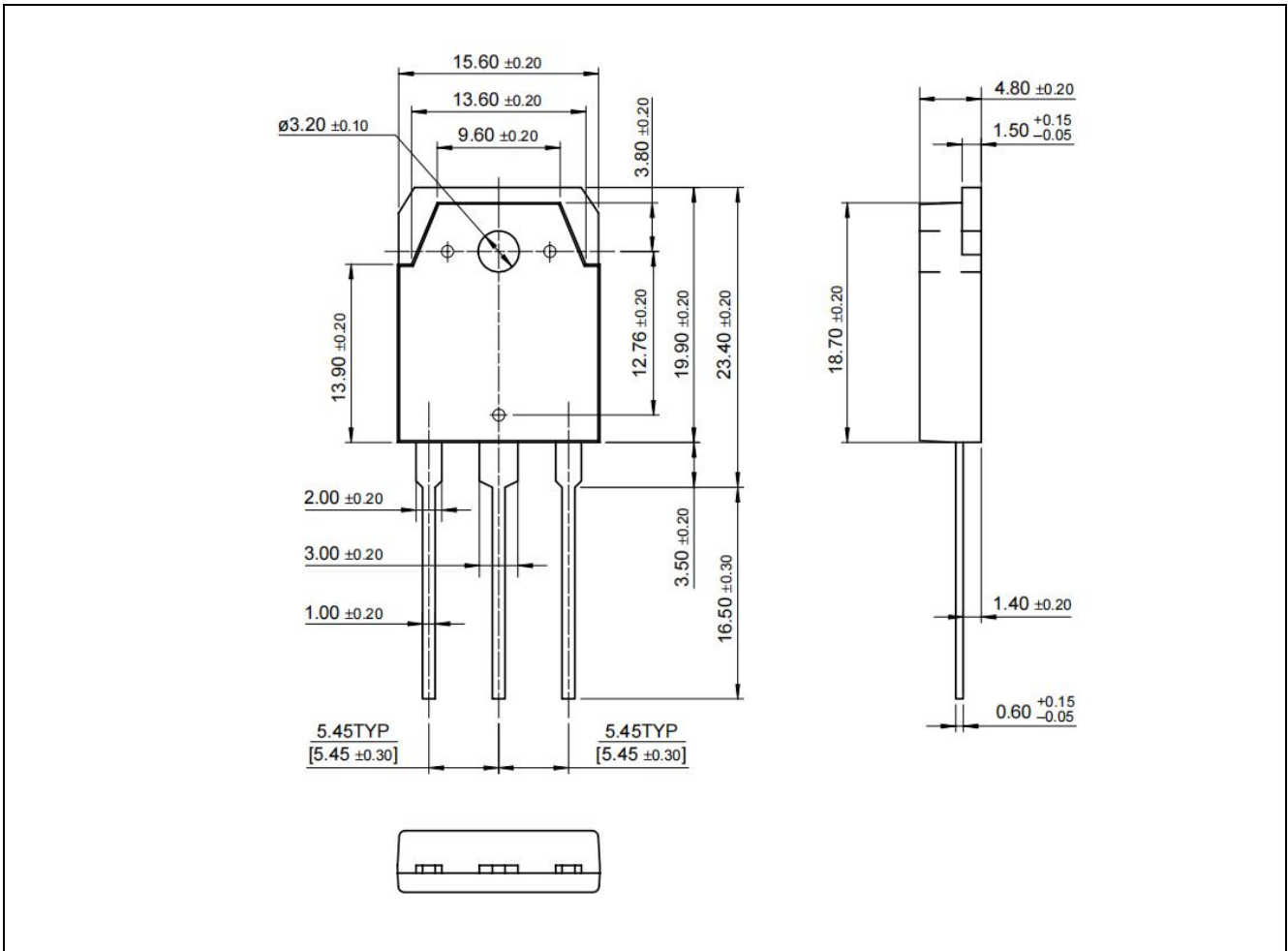

Fig.8 Transient thermal impedance Diode

Package Outlines (Unit: mm)

TO-3PN



***Important Usage Information and Disclaimer**

The specifications of Zhuhai Hypersemi Co., Ltd. products are not guarantees of product characteristics. They reflect typical performance expected in standard applications, which may vary with specific uses. Users must conduct prior testing for their applications and make necessary adjustments.

Users are responsible for the safety of applications utilizing our products and must implement adequate safety measures to prevent physical injury, fire, or other risks in case of product failure. It is the user's duty to ensure that application designs comply with all applicable laws and standards. Our products must not be used in any applications where a product failure could reasonably result in personal injury, unless specifically authorized in a signed document by Zhuhai Hypersemi Co., Ltd.

No representations or warranties are made regarding the accuracy or completeness of this information, including any claims of non-infringement of third-party intellectual property rights. Zhuhai Hypersemi Co., Ltd. assumes no liability for any applications or uses of its products and does not grant any licenses to its intellectual property rights or those of others. We also make no claims regarding non-infringement of third-party intellectual property rights that may arise from applications.

Due to technical requirements, our products may contain hazardous substances. For details, please contact your nearest sales office. This document replaces all previous information and may be updated. We reserve the right to make changes.